

T18 Series Overhead Cube Clamp

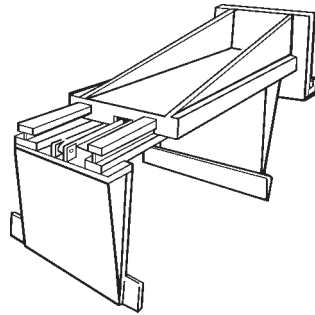

Hydraulic Requirements: Double function auxiliary kit

Model No.	Capacity @ 24" LC	Range Inside Pads	Mtg	Weight	ET	HCG	VCG
T18-40-13-55	4000	13 - 55	III	1200	8	30	18

➔ **Note:** For fork mounted unit add "F" to the end of the model no.

Maximum Pressure

2250 psi (150 bar)

Recommended Flow

6 gpm (27 litres)

Optional Auxiliary Hydraulics

- 3 way pressure reducing valve
- Variable pressure reducing valve
- Pressure gauge
- Quick disconnect couplings

Things we need to know...

- ✓ Weight of Load
- ✓ Max. Width of Load
- ✓ Min. Width of Load
- ✓ Type of Product
- ✓ Height of Load
- ✓ Length of Load
- ✓ Forklift Capacity