

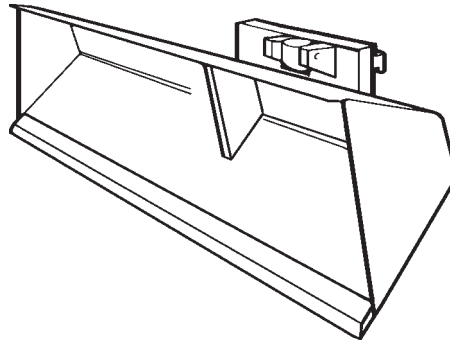

## T20 Series Scoop Bucket



**Hydraulic Requirements:** Single function auxiliary kit

| Model No. | Capacity @ 24" LC | Width | Weight | ET | HCG | VCG | Volume (Cub. yds) |
|-----------|-------------------|-------|--------|----|-----|-----|-------------------|
| T20-50-48 | 2500              | 48    | 850    | 12 | 8   | 12  | 0.5               |
| T20-75-60 | 3500              | 60    | 975    | 12 | 9   | 14  | 0.8               |

➔ **Note:** For fork mounted unit add "F" to the end of the model no.

### Maximum Pressure

2250 psi (150 bar)

### Recommended Flow

6 gpm (27 litres)

### Optional Auxiliary Hydraulics

3 way pressure reducing valve

Variable pressure reducing valve

Pressure gauge

Quick disconnect couplings

**Things we need to know...**

✓ Type of Product  
✓ Make of Forklift

✓ Forklift Capacity  
✓ Fork or Carriage Dimensions